

| | |
|-------------------------|---|
| SFPTURKIYESBD(A)SM005GD | 1.25G SFP Bi-Di 1310nm TX/1550nm RX 5Km SMF LC DDM |
| SFPTURKIYESBD(B)SM005GD | 1.25G SFP Bi-Di 1550nm TX/1310nm RX 5Km SMF LC DDM |
| SFPTURKIYESBD(A)SM020GD | 1.25G SFP Bi-Di 1310nm TX/1550nm RX 20Km SMF LC DDM |
| SFPTURKIYESBD(B)SM020GD | 1.25G SFP Bi-Di 1550nm TX/1310nm RX 20Km SMF LC DDM |
| SFPTURKIYESBD(A)SM040GD | 1.25G SFP Bi-Di 1310nm TX/1550nm RX 40Km SMF LC DDM |
| SFPTURKIYESBD(B)SM040GD | 1.25G SFP Bi-Di 1550nm TX/1310nm RX 40Km SMF LC DDM |

Features :

- GiSObit Ethernet
- GiSObit Fiber Channel
- SFP MSA package with Simplex LC connector
- Compliant with IEEE 802.3ah,
- Digital diagnostic monitor interface compatible with SFF-8472
- transmission with 9/125 μ m SMF
- Single 3.3V Power Supply and LVTTTL Logic
- Very low EMI and excellent ESD protection
- Operating Case Temperature: 0°C ~+70°C
- RoHS compliant
- Class 1 laser safety certified

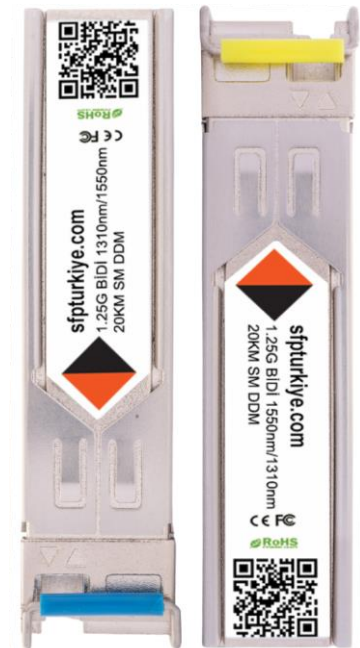

Absolute Maximum Ratings

Table 1- Absolute Maximum Ratings

| Parameter | Symbol | Min. | Typ. | Max. | Unit | Notes |
|-----------------------------|--------|------|------|------|------|-------|
| Supply Voltage | Vcc | -0.5 | - | +3.6 | V | |
| Storage Temperature | Ts | -40 | - | 85 | °C | |
| Operating Relative Humidity | RH | +5 | - | +95 | % | |

Recommended Operating Conditions

Table 2- Recommended operating Conditions

| Parameter | Symbol | Min. | Typ. | Max. | Units | Notes |
|----------------------------|--------|------|------|------|-------|-------|
| Operating Case Temperature | Tc | 0 | - | 70 | °C | |
| Power Supply Voltage | Vcc | 3.14 | 3.3 | 3.46 | V | |
| Power Supply Current | Icc | - | - | 300 | mA | |
| Power Dissipation | Pd | - | - | 1 | W | |



| | | | | | | |
|-----------|--|---|------|---|------|--|
| Data Rate | | - | 1250 | - | Mbps | |
|-----------|--|---|------|---|------|--|

Electrical Characteristics

Table 3- Electrical Characteristics

| Parameter | Symbol | Min. | Typ. | Max. | Units | Notes | |
|--------------------------------|-------------------|----------|------|------|--------------|-------|--|
| Differential Data Input Swing | $V_{in\ p-p}$ | 200 | - | 2400 | mV | 1 | |
| Input Differential Impedance | R_{IN} | 80 | 100 | 120 | Ω | | |
| Tx_Disable | Laser Disable | V_{OH} | 2.0 | - | $V_{CC}+0.5$ | V | |
| | Normal Operation | V_{OL} | GND | - | $GND+0.8$ | V | |
| TX_Fault | Transmitter Fault | V_{OH} | 2.0 | - | $V_{CC}+0.5$ | V | |
| | Normal Operation | V_{OL} | GND | - | $GND+0.8$ | V | |
| Differential Data Output Swing | $V_{out\ p-p}$ | 750 | 900 | 1050 | mV | 2 | |
| Rx_LOS | Los Signal | V_{OH} | 2.0 | - | $V_{CC}+0.5$ | V | |
| | Normal Operation | V_{OL} | GND | - | $GND+0.8$ | V | |

Note:

1. Internally AC coupled, input termination may be required for CML or LVPECL applications.
2. Internally AC coupled, CML differential output stage.



Optical Characteristics

Table 4-Optical Characteristics

| Parameter | Sym bol | Min. | Typ. | Max. | Unit | | Note s |
|---------------------------------------|--------------------------------|------|------|------|------|--------------------|--------|
| Transmitter | | | | | | | |
| Average Output Power | P _{OUT} | -9 | | -3 | dBm | 5km/20km | 1 |
| | | -5 | | 0 | | 40km | |
| | | 0 | | 5 | | 80km | |
| Mean Wavelength | λ | 1290 | 1310 | 1330 | nm | SFPTURKIYESBD(A)SM | |
| | | 1480 | 1490 | 1500 | | | |
| | | 1540 | 1550 | 1560 | | SFPTURKIYESBD(B)SM | |
| Extinction Ratio | ER | 9 | - | - | dB | | |
| Spectral Width(RMS) | Δλ | - | - | 1 | nm | | |
| P _{Out} @TX Disable Asserted | P _{OUT} | - | - | -45 | dB | | |
| Rise/Fall Time (20%~80%) | T _r /T _f | | | 260 | ps | | |
| Optical Eye Mask | IEEE 802.3ah Compliant | | | | | | |
| Receiver | | | | | | | |
| Receiver Power | Pin | | | -18 | dBm | 5km | 2 |
| | | | - | -23 | | 20km/40km/80km | |
| Centre Wavelength | λ _c | 1290 | 1310 | 1330 | nm | SFPTURKIYESBD(B)SM | |
| | | 1480 | 1490 | 1500 | | | |
| | | 1530 | 1550 | 1570 | | SFPTURKIYESBD(A)SM | |
| Receiver Overload | R _{sens,high} | -3 | - | - | dBm | | |
| Damage Threshold For Receive | P _{in,damage} | 0 | | | | | |
| Receiver Reflectance | RX _r | - | - | -12 | dB | | |
| LOS De-Assert | LOS _D | | | - | dB | | |
| | | - | - | -25 | | 20km/40km/80km | |



| | | | | | | | |
|----------------|------------------|-----|---|---|----|----------------|--|
| LOS Assert | LOS _A | -35 | - | - | dB | 20km/40km/80km | |
| LOS Hysteresis | | 0.5 | | - | | | |

Note:

1. Coupled into 9/125 SMF.
2. Measured with PRBS 2⁷-1 test pattern @1.25Gbps.BER=10E-12

Recommended Interface Circuit

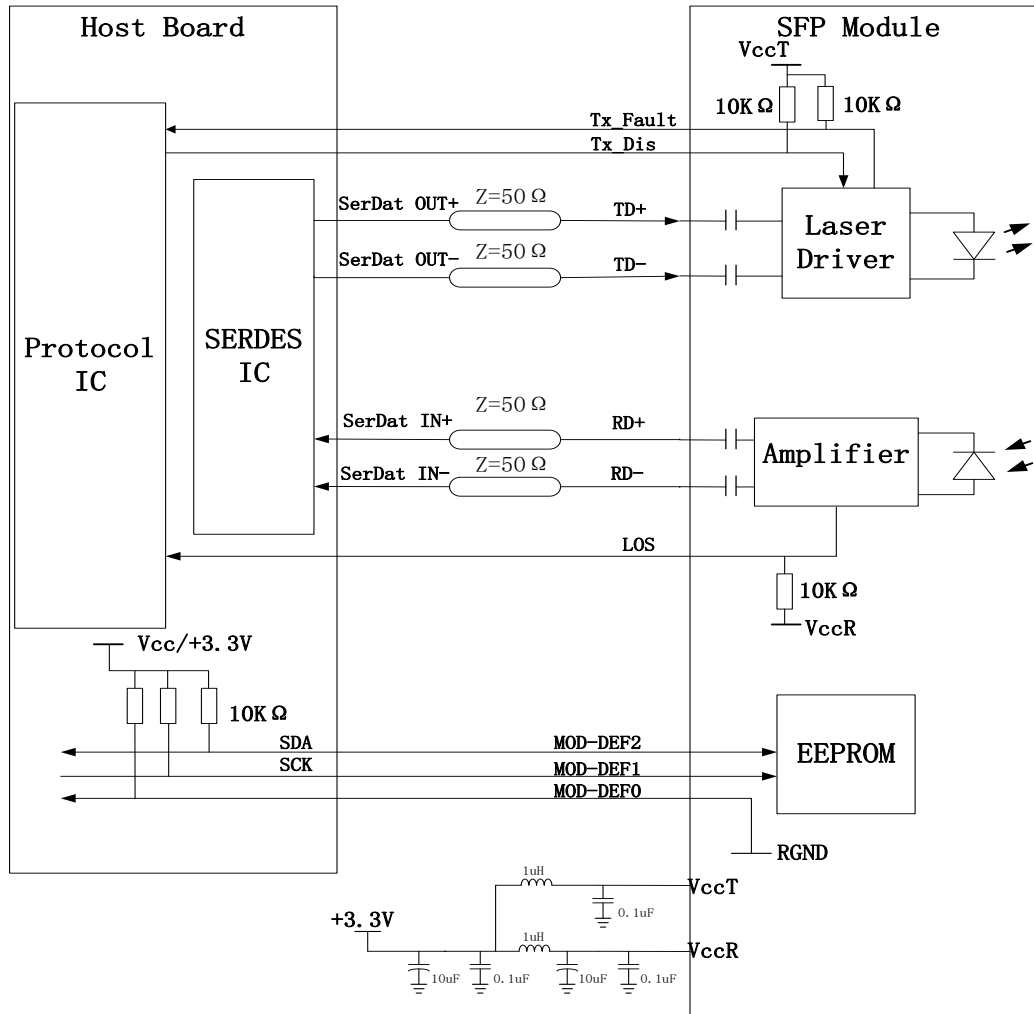

Figure 1, Recommended Interface Circuit

Pin arrangement



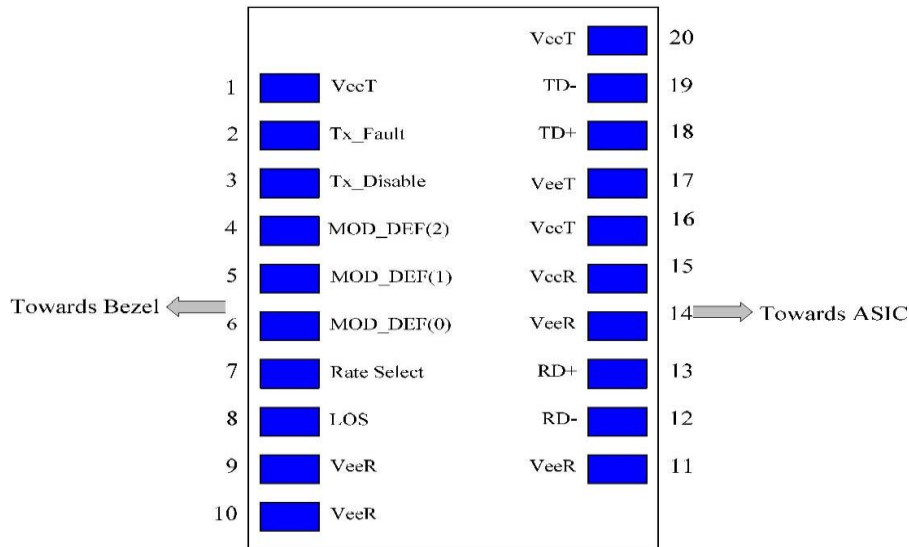

Figure 2, Pin View

Table 5-Pin Function Definitions

| Pin | Name | FUNCTION | Plug Seq. | Notes |
|-----|-------------|------------------------------|-----------|-----------|
| 1 | VeeT | Transmitter Ground | 1 | |
| 2 | TX Fault | Transmitter Fault Indication | 3 | 1 |
| 3 | TX Disable | Transmitter Disable | 3 | 2, |
| 4 | MOD-DEF2 | Module Definition 2 | 3 | 3 |
| 5 | MOD-DEF1 | Module Definition 1 | 3 | 3 |
| 6 | MOD-DEF0 | Module Definition 0 | 3 | 3 |
| 7 | Rate Select | Not Connect | 3 | |
| 8 | LOS | Loss of Signal | 3 | 4 |
| 9 | VeeR | Receiver Ground | 1 | |
| 10 | VeeR | Receiver Ground | 1 | |
| 11 | VeeR | Receiver Ground | 1 | |
| 12 | RD- | Inv. Received Data Out | 3 | |
| 13 | RD+ | Received Data Out | 3 | |
| 14 | VeeR | Receiver Ground | 1 | |
| 15 | VccR | Receiver Power | 2 | 3.3V ± 5% |
| 16 | VccT | Transmitter Power | 2 | 3.3V ± 5% |
| 17 | VeeT | Transmitter Ground | 1 | |
| 18 | TD+ | Transmit Data In | 3 | |
| 19 | TD- | Inv. Transmit Data In | 3 | |
| 20 | VeeT | Transmitter Ground | 1 | |

Note:

- TX Fault is open collector output which should be pulled up externally with a 4.7K ~10KΩ resistor on the host board to voltage between 2.0V and V_{CC}+0.3V. Logic 0 indicates normal operation; logic 1 indicates a laser fault of some kind. In the low state, the output will be pulled to less than 0.8V.



2. TX Disable input is used to shut down the laser output per the state table below. It is pulled up within the module with a 4.7~ 10K resistor.

| | |
|------------------------|----------------------|
| Low (0- 0.8V): | Transmitter on |
| Between (0.8V and 2V): | Undefined |
| High (2.0 – VccT): | Transmitter Disabled |
| Open: | Transmitter Disabled |
3. MOD-DEF 0, 1, 2. These are the module definition pins. They should be pulled up with a 4.7~10K resistor on the host board to supply less than VccT+0.3V or VccR+0.3V.
 - MOD-DEF 0 is grounded by the module to indicate that the module is present.
 - MOD-DEF 1 is clock line of two wire serial interface for optional serial ID.
 - MOD-DEF 2 is data line of two wire serial interface for optional serial ID.
4. LOS (Loss of signal) is an open collector output, which should be pulled up with a 4.7k~10kΩ resistor on the host board to a voltage between 2.0V and Vcc+0.3V. Logic 0 indicates normal operation; logic 1 indicates loss of signal. In the low state, the output will be pulled to less than 0.8V.

Digital Diagnostic Memory Map

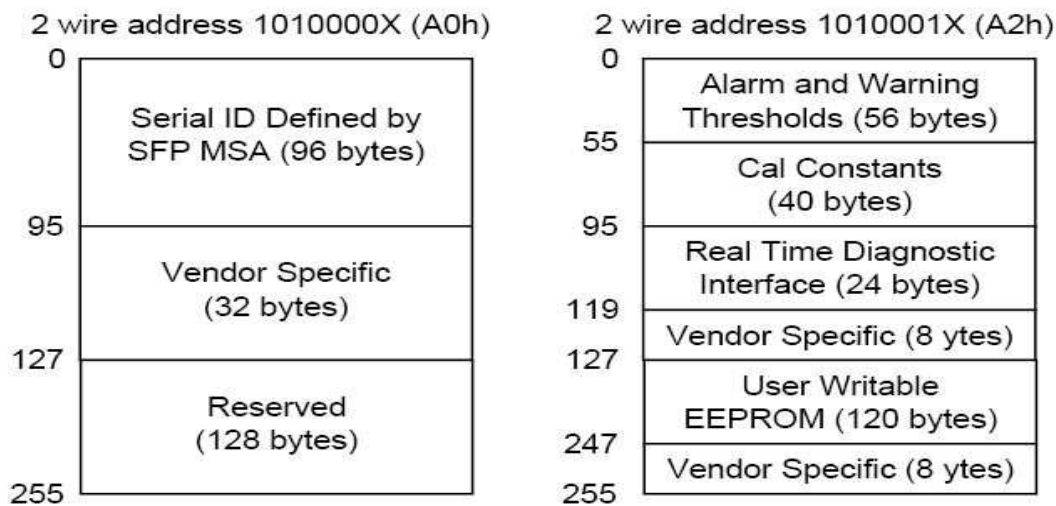

Figure 3, memory map

Mechanical Diagram



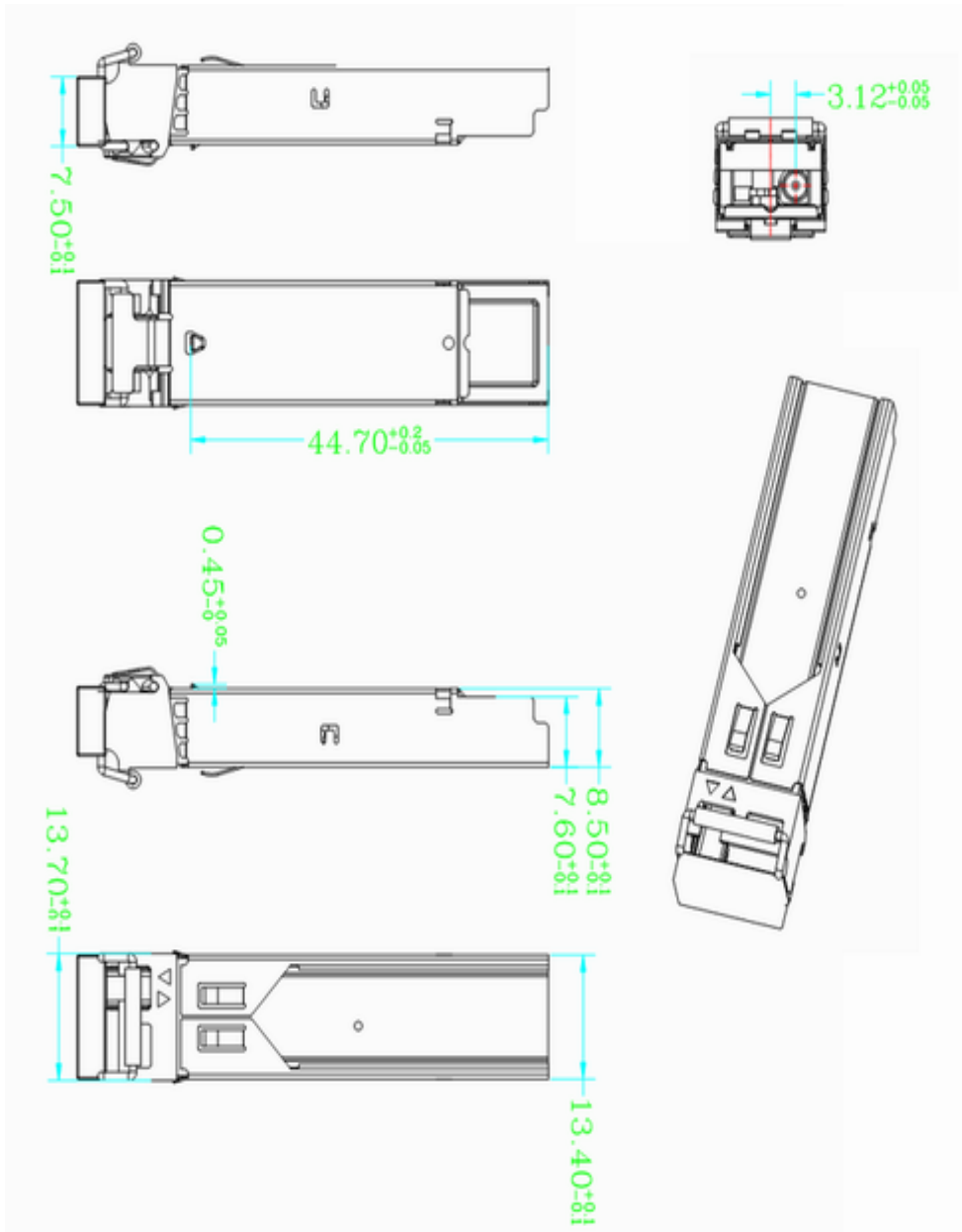

Figure 4, mechanical diagram



Ordering Information

Table 6-ordering information

| Part No. | DDM | Tx Wavelength | Rx Wavelength | Fiber Type | Optical Interface | Distance |
|-------------------------|-----|---------------|---------------|------------|-------------------|----------|
| SFPTURKIYESBD(A)SM005GD | YES | 1310nm | 1550nm | SMF | SC/LC | 5km |
| SFPTURKIYESBD(B)SM005GD | YES | 1550nm | 1310nm | SMF | SC/LC | 5km |
| SFPTURKIYESBD(A)SM020GD | YES | 1310nm | 1550nm | SMF | SC/LC | 20km |
| SFPTURKIYESBD(A)SM020GD | YES | 1550nm | 1310nm | SMF | SC/LC | 20km |
| SFPTURKIYESBD(A)SM040GD | YES | 1310nm | 1550nm | SMF | SC/LC | 40km |
| SFPTURKIYESBD(B)SM040GD | YES | 1550nm | 1310nm | SMF | SC/LC | 40km |

● Notice

SFPTURKIYE reserves the right to make changes to the product(s) or information contained herein without notice. No liability is assumed as a result of their use or application. No rights under any patent accompany the sale of any such product(s) or information. Copyright © SFPTURKIYE.COM All Rights Reserved.

E-mail: info@sfpturkiye.com

Web : <http://www.sfpturkiye.com>

